

**TYPE "A" PLATING**  
CITY POSTED SPEEDS OF GREATER THAN 25 MPH OR BUS & TRUCK ROUTE

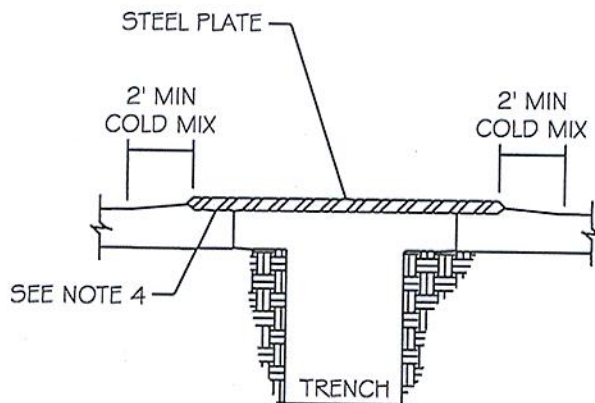

**TYPE "B" PLATING**  
CITY POSTED SPEEDS OF 25 MPH AND UNDER

TRENCH WIDTH	MINIMUM PLATE THICKNESS
10" (0.25 M)	1/2" (13 MM)
1'-11" (0.58 M)	3/4" (19 MM)
2'-7" (0.80 M)	7/8" (22 MM)
3'-5" (1.04 M)	1" (25 MM)
5'-3" (1.6 M)	1 1/4" (32 MM)

NOTES:

1. WHEN BACKFILLING OPERATIONS CANNOT BE PROPERLY COMPLETED WITHIN A WORK DAY, STEEL PLATES SHALL BE INSTALLED USING EITHER TYPE "A" OR TYPE "B" PLATING METHODS, OR AS DIRECTED BY CITY ENGINEER. THE CONTRACTOR IS RESPONSIBLE FOR MAINTENANCE OF THE STEEL PLATES, SHORING OR BRACING OF THE TRENCH AND ENSURING THAT THEY MEET THE MINIMUM SPECIFICATIONS OF CALTRANS TR-0157.
2. USE OF STEEL PLATE BRIDGING SHOULD NOT EXCEED 4 CONSECUTIVE WORKING DAYS IN ANY GIVEN WEEK.
3. THE TRENCH SHALL BE ADEQUATELY SHORED OR BRACED TO SUPPORT THE STEEL PLATE BRIDGING AND TRAFFIC LOADS.
4. THE CONTRACTOR SHALL PROVIDE ADEQUATE OVERLAP OF PLATE ASPHALT TO ASSURE NO SLIPPAGE OF PLATE AND NO COLLAPSING OF TRENCH. PLATES SHALL BE PINNED TO THE PAVEMENT SURFACE, WITH A MINIMUM OF 2 DOWELS PRE-DRILLED INTO THE CORNERS OF THE PLATE AND DRILLED 2" INTO THE PAVEMENT, WITH A MINIMUM 1' OVERLAP ONTO EXISTING STABLE MATERIAL. WHEN STEEL PLATES ARE REMOVED, THE DOWEL HOLES IN THE PAVEMENT SHALL BE BACKFILLED WITH EITHER GRADED FINES OF ASPHALT CONCRETE MIX, CONCRETE SLURRY OR AN EQUIVALENT SLURRY THAT IS APPROVED BY CITY ENGINEER.
5. STEEL PLATES USED IN THE TRAVELED PORTION OF THE RIGHT OF WAY SHALL HAVE A SURFACE THAT WAS MANUFACTURED WITH A NOMINAL COEFFICIENT OF FRICTION (COF) OF 0.35 AS DETERMINED BY CALIFORNIA TEST METHOD 342 OR AS APPROVED BY CITY ENGINEER. SURFACING REQUIREMENTS ARE NOT NECESSARY FOR STEEL PLATES USED IN PARKING STRIPS, ON SHOULDERS NOT USED FOR TURNING MOVEMENTS, OR ON CONNECTING DRIVEWAYS, ETC. NOT OPEN TO THE PUBLIC. FOR SPANS GREATER THAN 5'-3", A STRUCTURAL DESIGN SHALL BE PREPARED BY A CALIFORNIA REGISTERED CIVIL ENGINEER.
6. ALL STEEL PLATES WITHIN THE RIGHT OF WAY, WHETHER USED IN OR OUT OF THE TRAVELED WAY, SHALL BE WITHOUT DEFORMATION.
7. A ROUGH ROAD SIGN (W8-8) WITH BLACK LETTERING ON AN ORANGE BACKGROUND SHALL BE USED IN ADVANCE OF STEEL PLATES IN ADDITION TO ANY OTHER REQUIRED CONSTRUCTION SIGNING.
8. "POSTED SPEED" DOES NOT INCLUDE TEMPORARY CONSTRUCTION SIGNING.



APPROVED BY: *[Signature]* DATE: 9/18/14

CITY ENGINEER GLEN W.C. KAU

REVISION	DESCRIPTION	BY	DATE

CITY OF COMPTON

EMERGENCY PLATE BRIDGING OF EXCAVATIONS

STANDARD PLAN NUMBER 151 | 1 of 1